



```
<Adressen>  
  <Adresse id="1234">  
    <Name> Mustermann </Name>  
    <PLZ> 722087 </PLZ>  
  </Adresse>  
</Adressen>
```

**in
action**

XML-in-Action 2001

Robert Landwehr, Christoph Gönnheimer

AW 221: Roboteransteuerung mit SOAP

Institut für Werkzeugmaschinen
und Betriebstechnik

wbk

Robert.Landwehr@mach.uni-karlsruhe.de ,
Christoph.Goennheimer@mach.uni-karlsruhe.de



DevGroup



Referenten

**Christoph
Gönnheimer**

Wissenschaftlicher
Mitarbeiter

**Robert
Landwehr**

Wissenschaftlicher
Mitarbeiter

Institut für
Werkzeugmaschinen und Betriebstechnik (wbk)
Universität Karlsruhe (TH)



Kommunikation in der AT

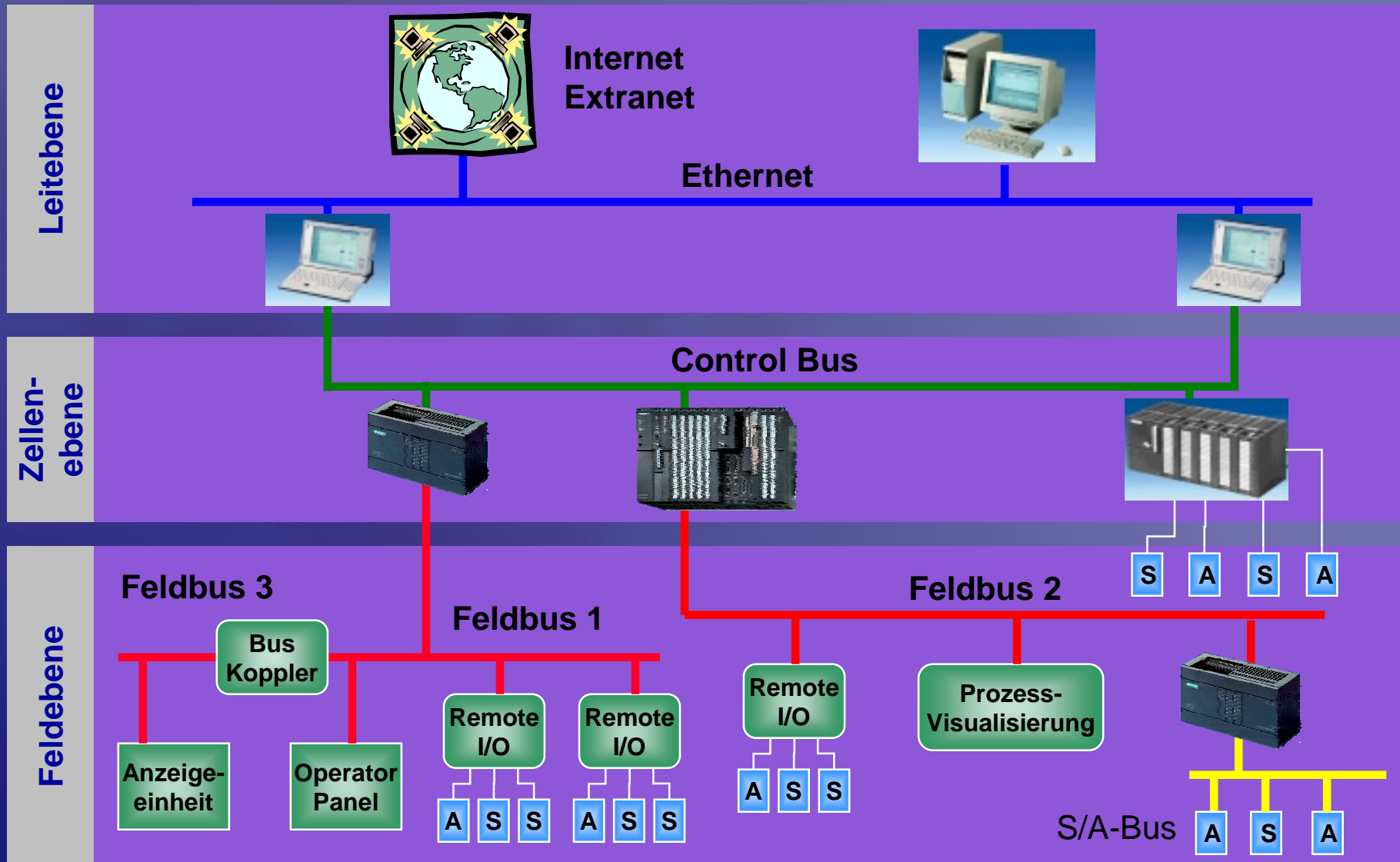

Automatisierung heute



Trend in der Automation

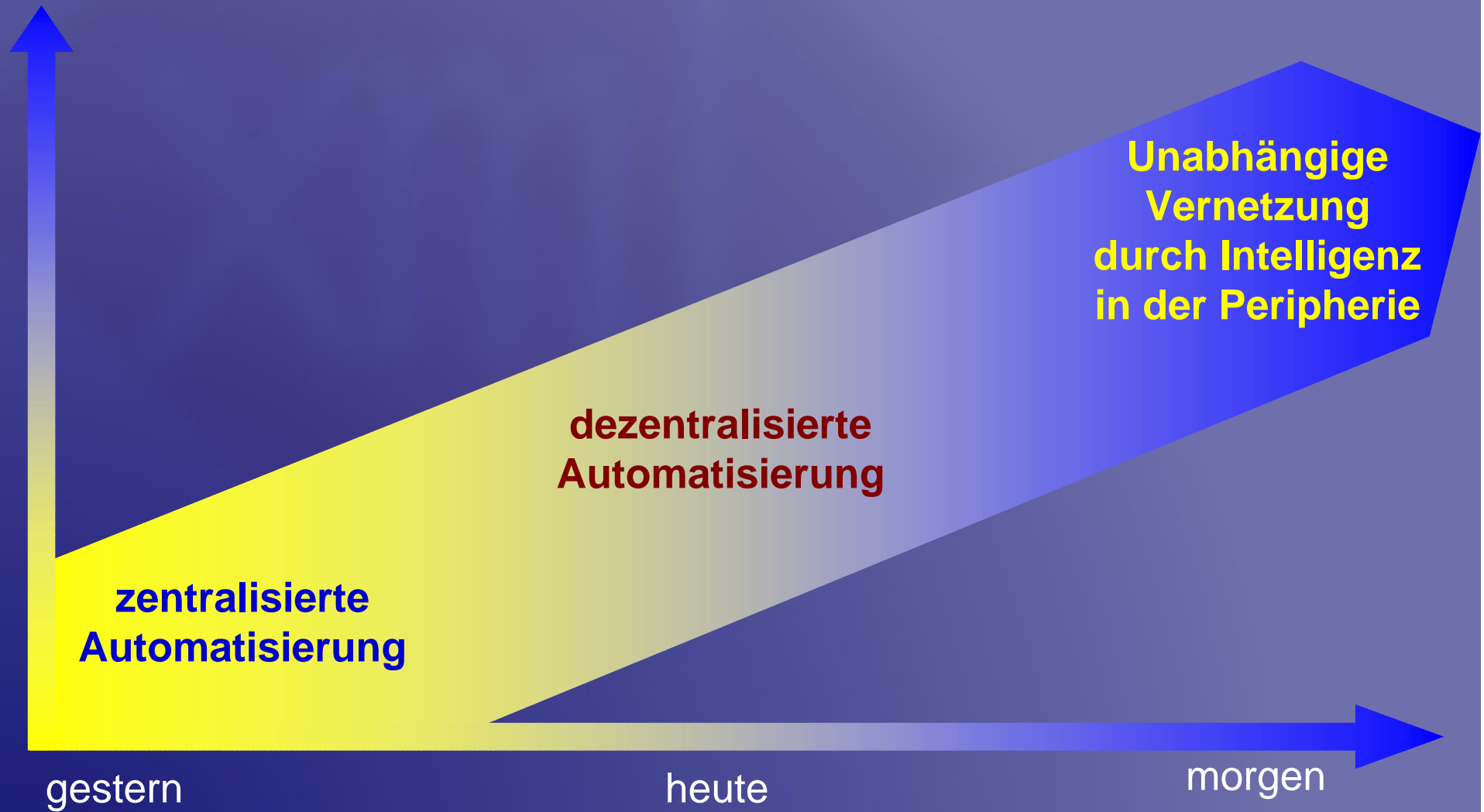

Vertikale Integration

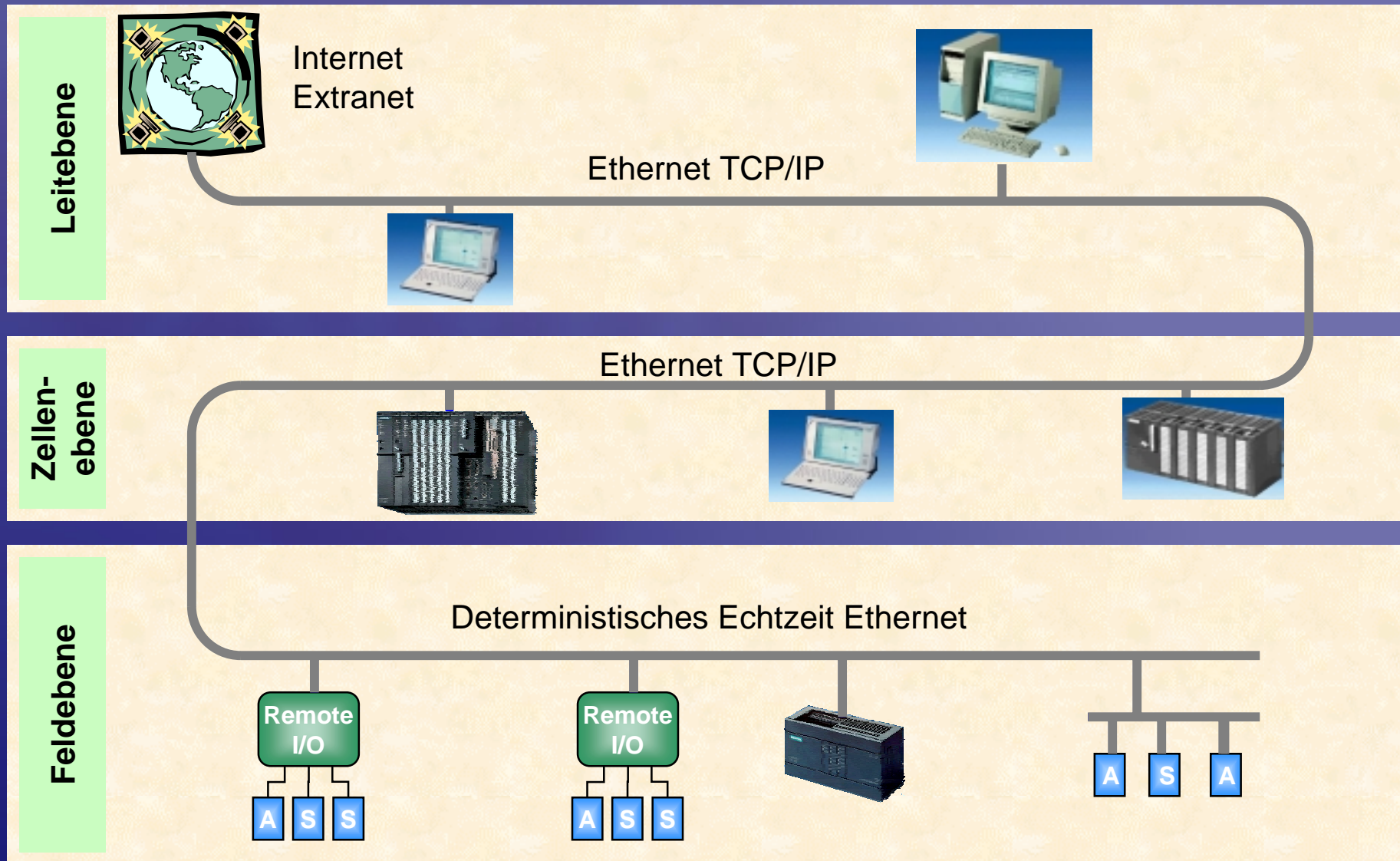

Durchgängiges Ethernet TCP/IP

Zwischenziel

Durchgängig: TCP/IP

PC (Programmieren u. Steuern)

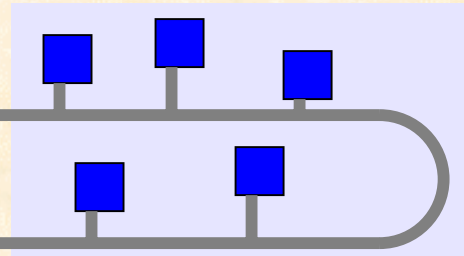

Legende:

→ Kommunikation über:
Ethernet (TCP/IP)

■ Steuerungs-
komponenten
- Sensoren
- Aktoren
- kleinere Gruppen von
Sensoren und Aktoren

Ziel

PC konfiguriert Netz

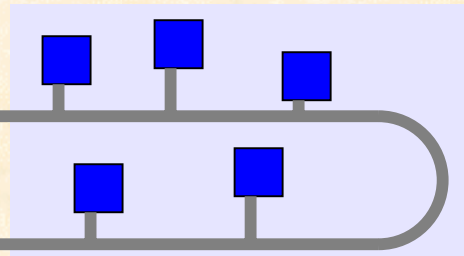

Komponenten werden parametrisiert
und Eigenschaften eingestellt.

PC zum Monitoring

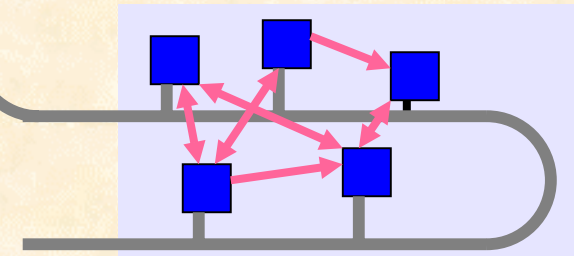

Komponenten arbeiten und
kommunizieren nur miteinander.

Sensor/Aktor an Ethernet ?

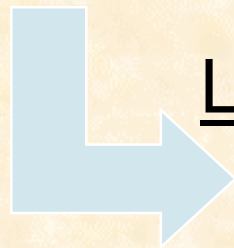
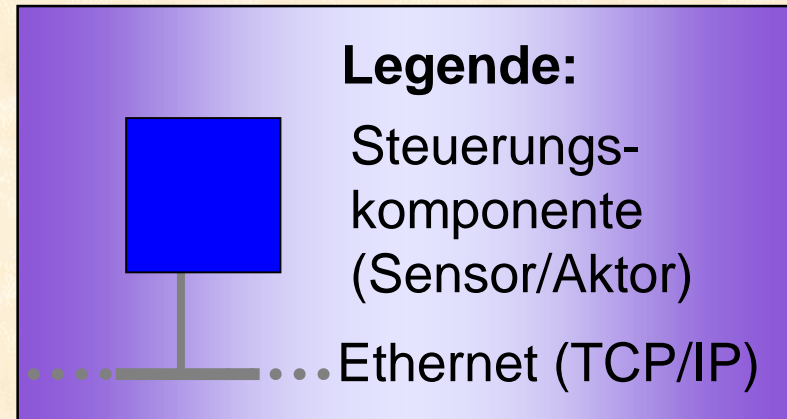
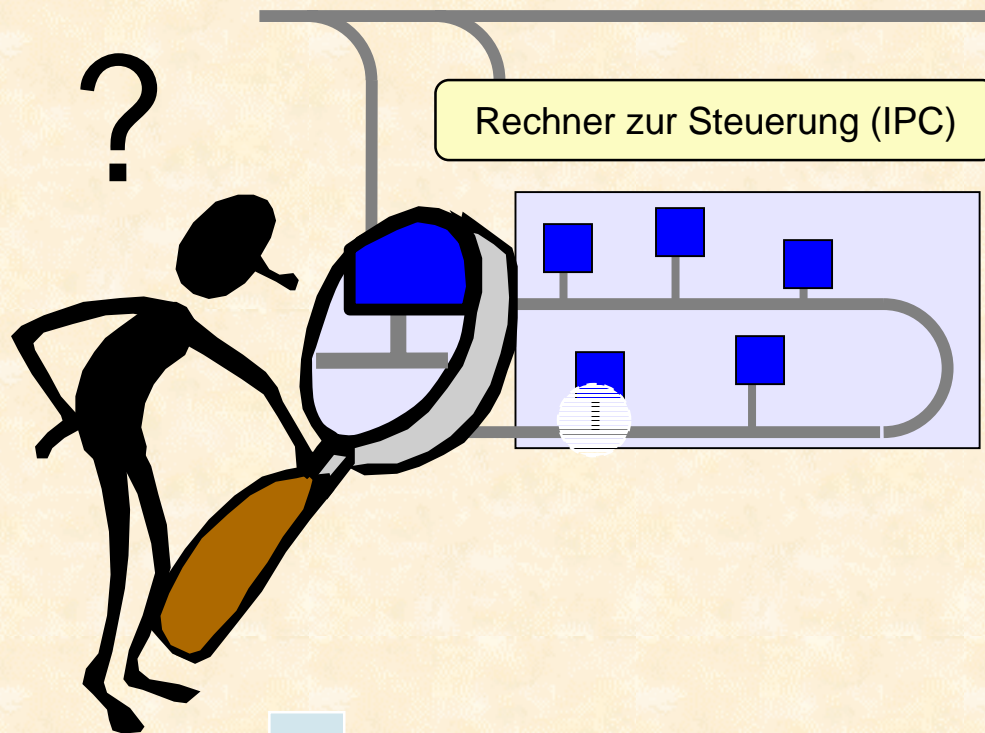

Lösung:

μ -Webservice-Provider
auf XML und SOAP Basis
für Sensor-/Aktoranbindung

„Low-cost“ μ -Webcontroller

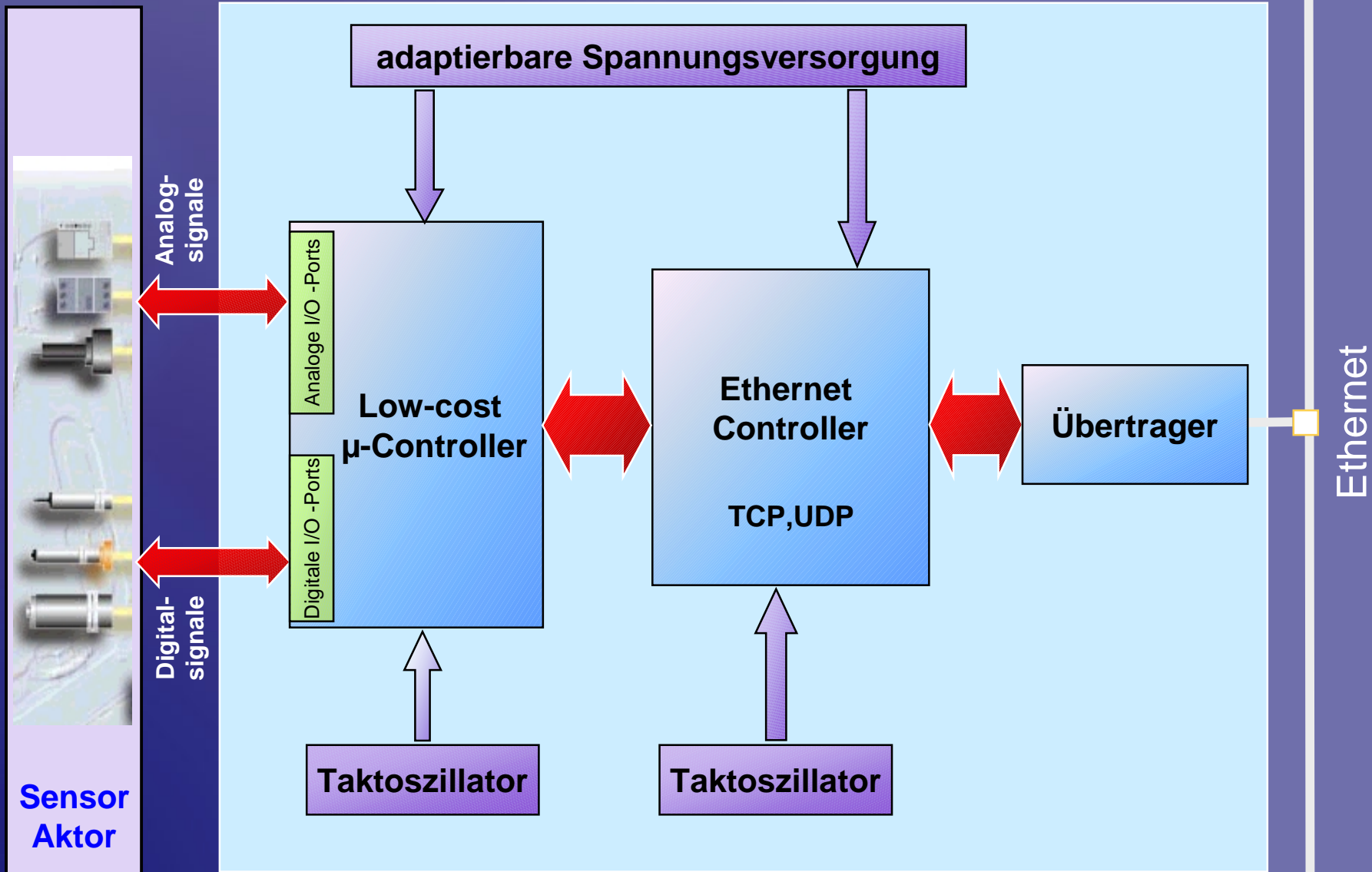

Versuchsaufbau μ -Web



Alt: 10x6 cm

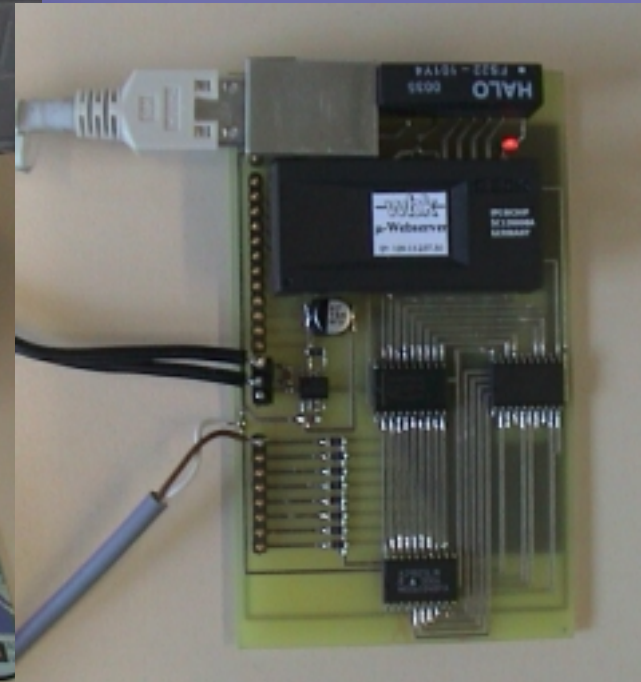

Neu: 4x3 cm

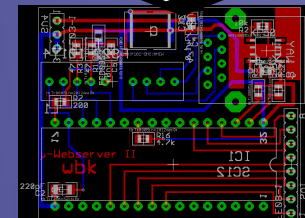

Deterministik und Echtzeitfähigkeit

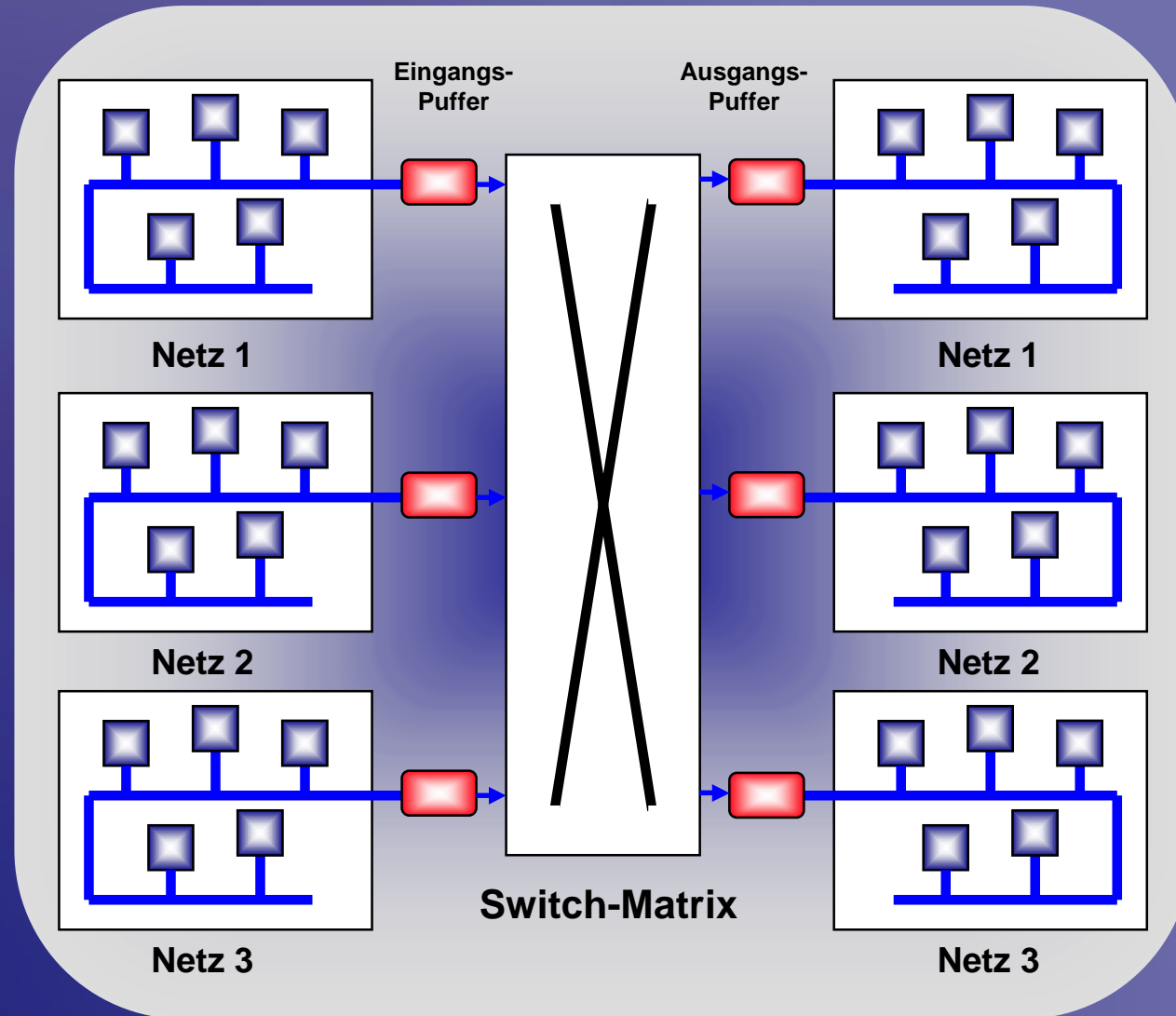

Switched Ethernet

Grundidee – SOAP in der AT

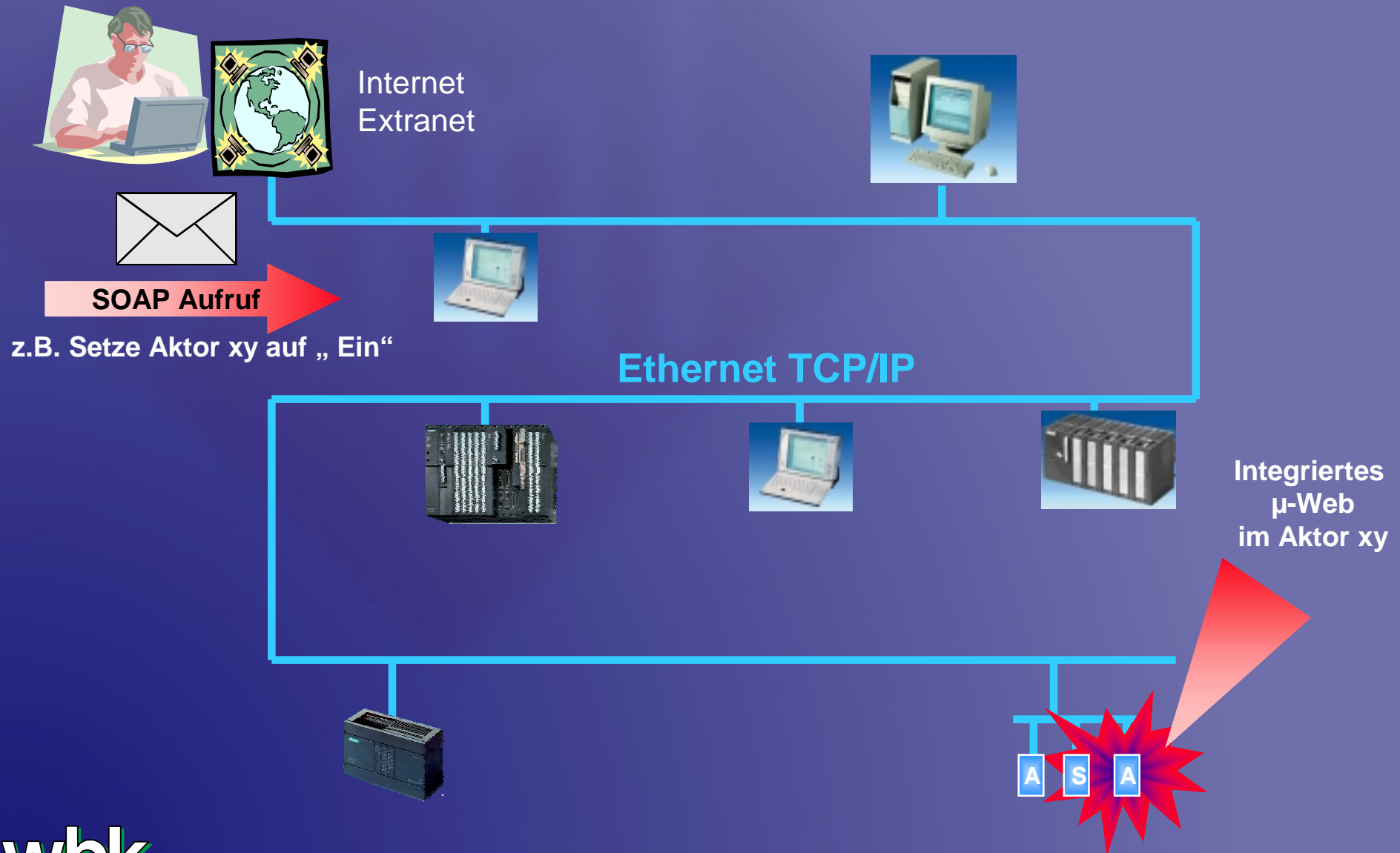

Kommunikation

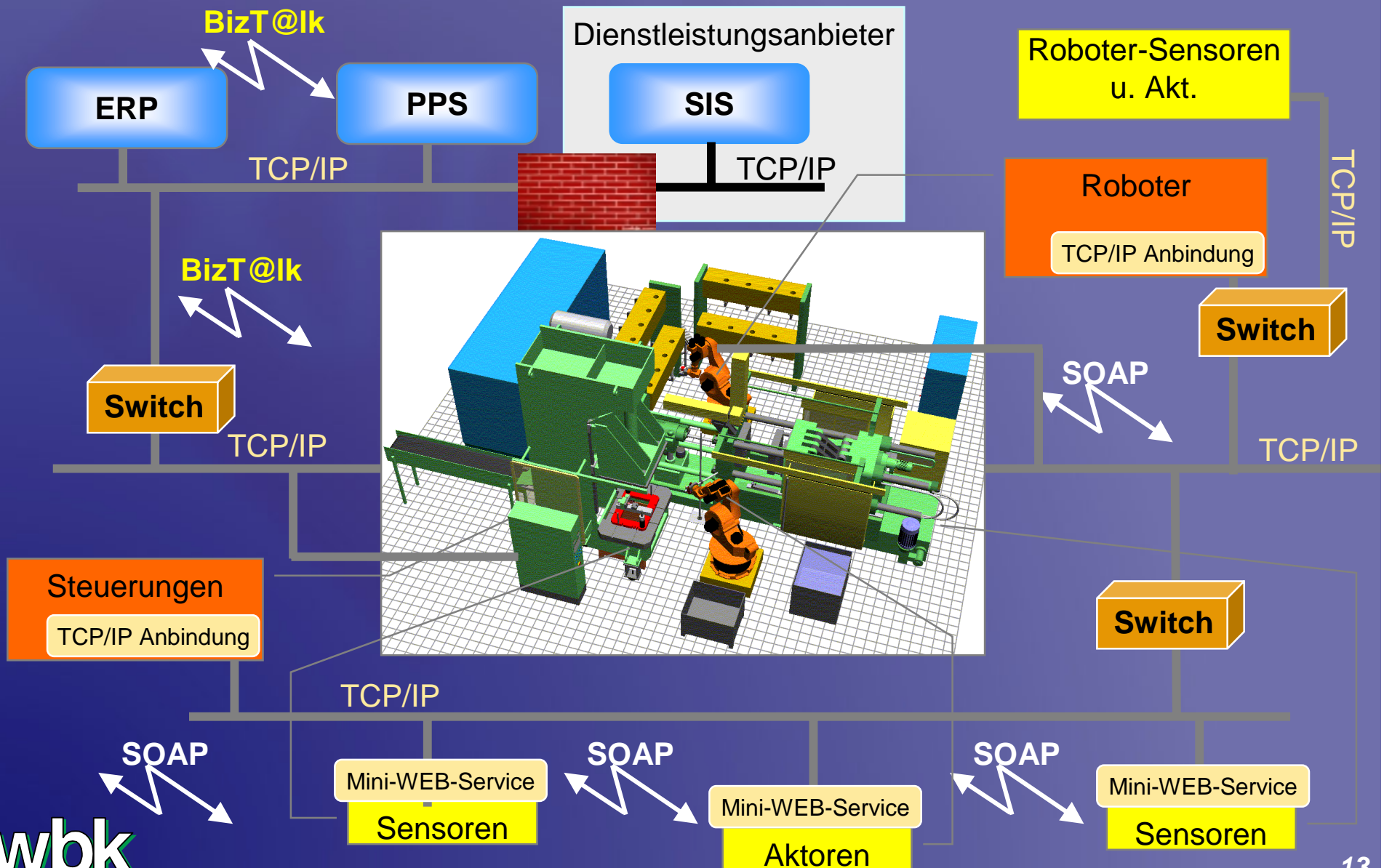

SOAP



Aufbau eines SOAP- Envelope

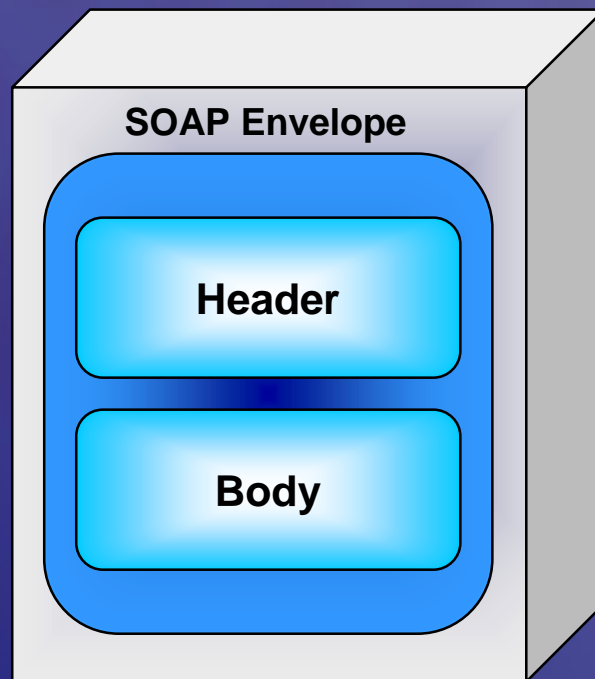

Aufbau einer HTTP-Nachricht

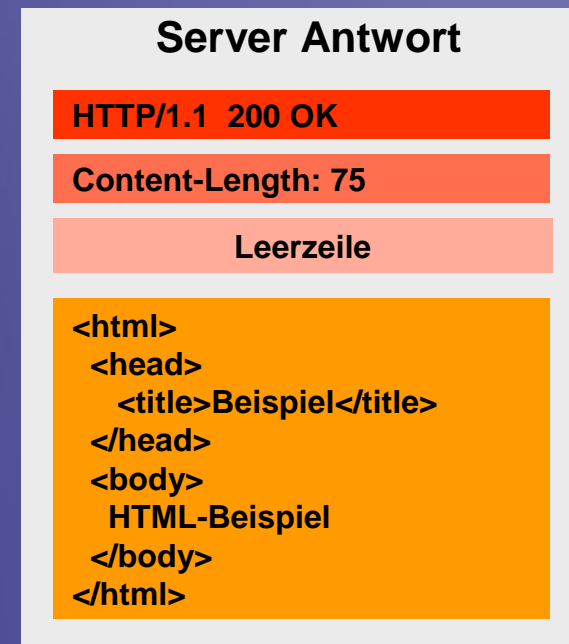
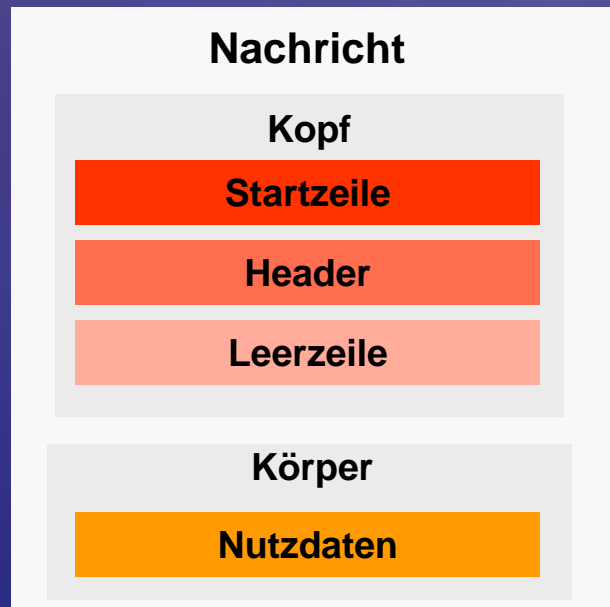

XML in der Automatisierung

XML

```
<element name='greiferauf'>  
  <type>  
    <element name='clientsessionid' type='dt:string'/>  
  </type>  
</element>  
<element name='greiferaufResponse'>  
  <type>  
    <element name='return' type='dt:string'/>  
  </type>  
</element>
```

XML trennt die Struktur eines Dokumentes von ihrem Inhalt

XML basiert auf der Textform, was Transparenz und Portabilität ermöglicht (nicht wie bei DCOM)

XML ist sehr flexibel und lässt sich gut erweitern (extensible markup)

Beispiel eines SOAP-Aufrufs

Aufruf

```
POST /HTTP/1.1
Host: wbkpc073.mach.uni-karlsruhe.de
<?xml version="1.0"?>
<SOAP:Envelope xmlns:SOAP=
"http://schemas.xmlsoap.org/soap/envelope/"
SOAP:encodingStyle=
"http://schemas.xmlsoap.org/soap/encoding/">
<SOAP:Body>
<greiferauf>
<clientsessionid>44</clientsessionid>
</greiferauf>
</SOAP:Body>
</SOAP:Envelope>
```

Antwort

```
HTTP/1.1 200 OK
Content-Type: text/xml
Content-Length: xxx
<?xml version="1.0"?>
<SOAP:Envelope xmlns:SOAP=
"http://schemas.xmlsoap.org/soap/envelope/"
SOAP:encodingStyle=
"http://schemas.xmlsoap.org/soap/encoding/">
<SOAP:Body>
<greiferaufResponse>
<return>0</return>
</greiferaufResponse>
</SOAP:Body>
</SOAP:Envelope>
```

SOAP-Toolkit

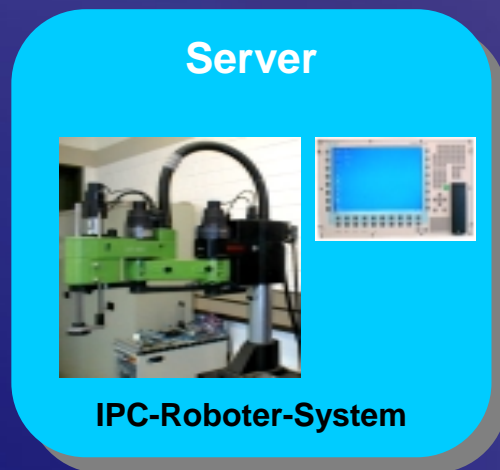
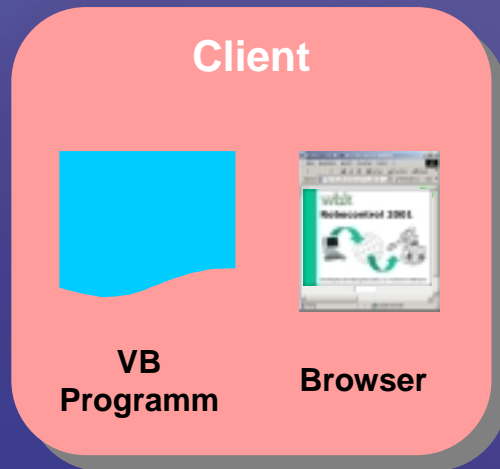

Microsoft SOAP-Toolkit

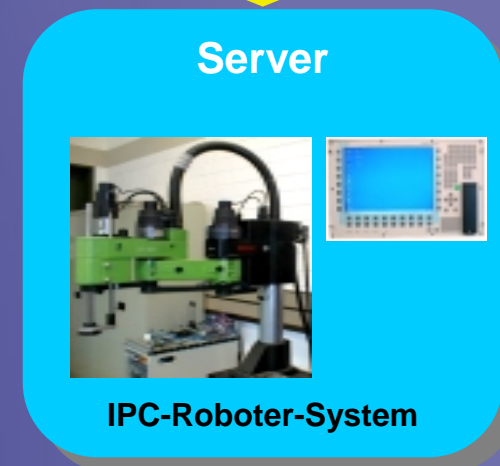
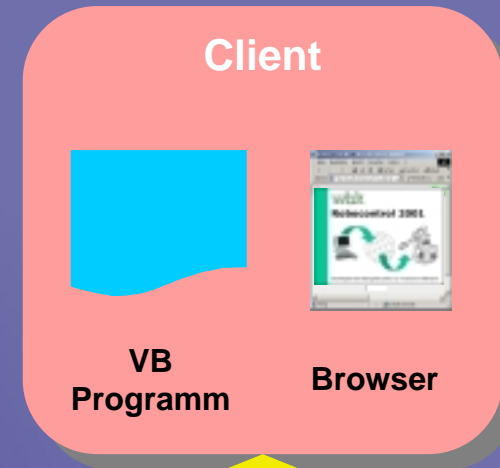
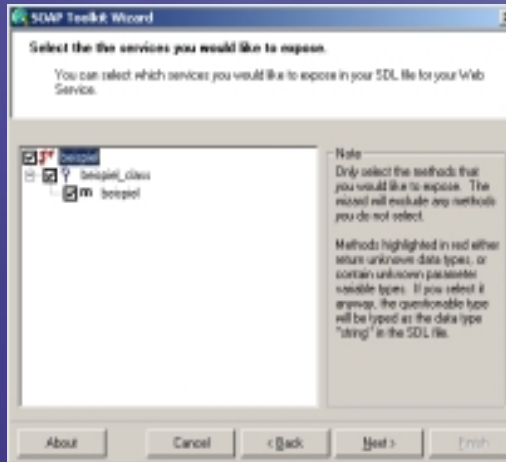

System Detailansicht

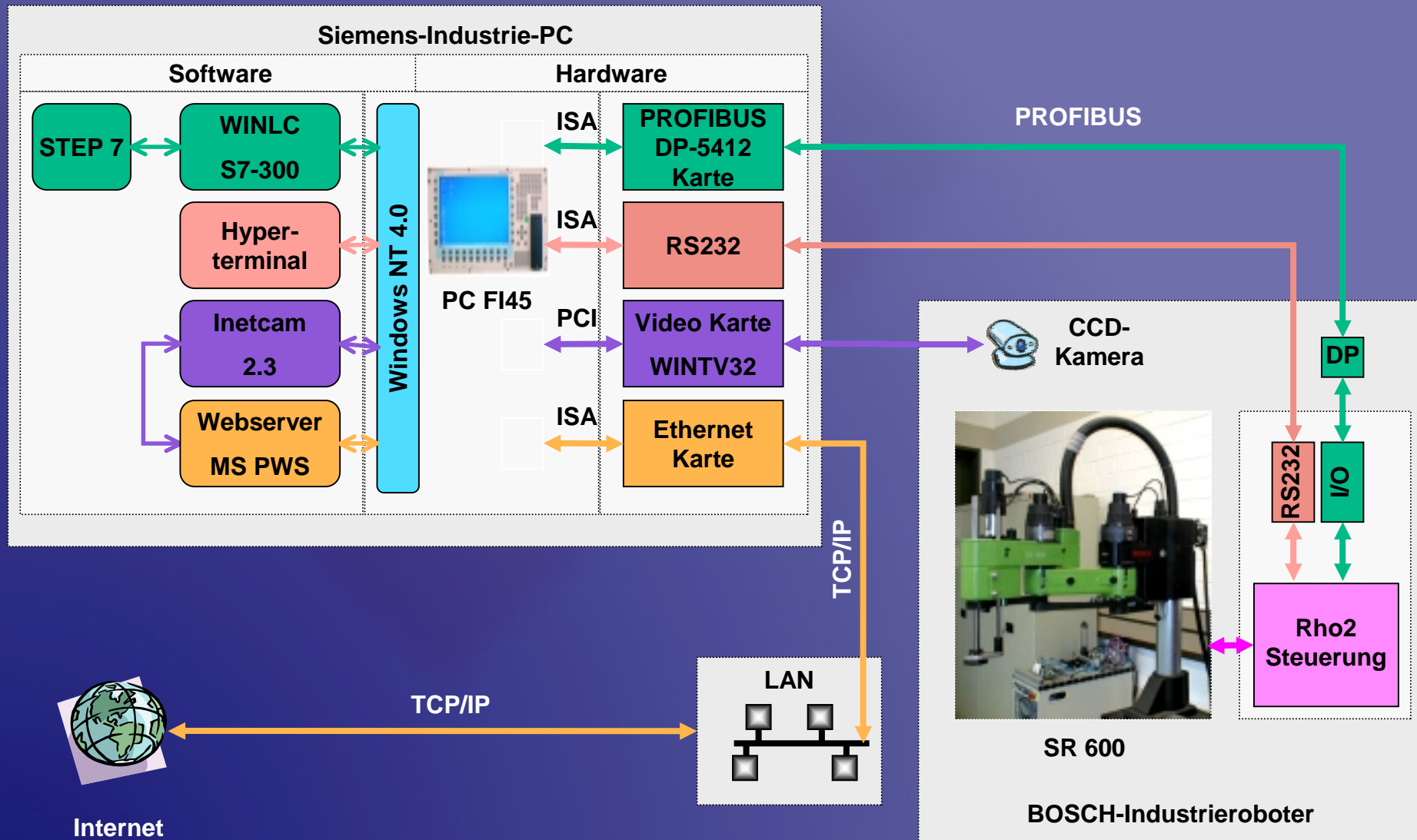

Programm Übersicht

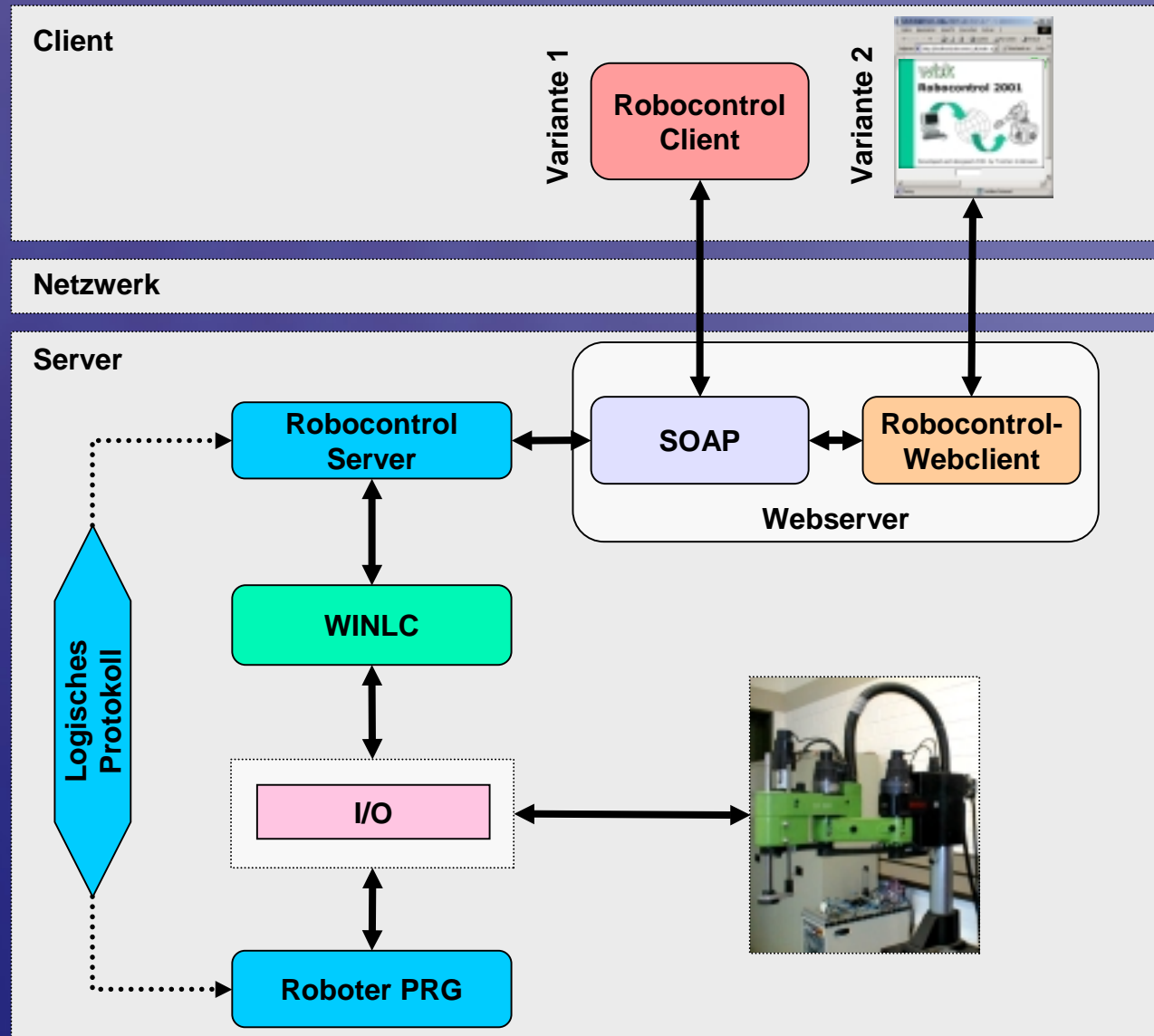

Programm Detailansicht

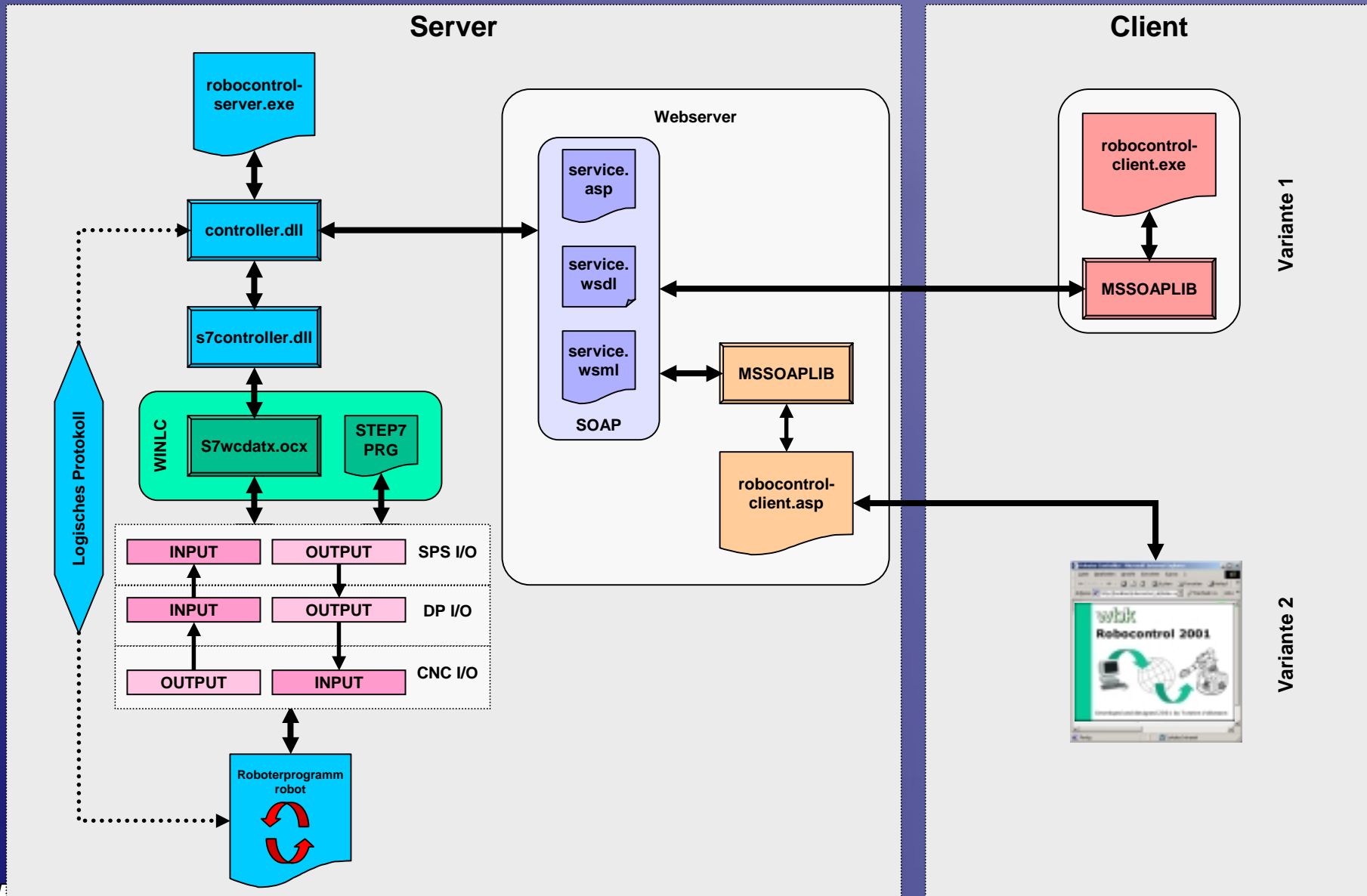

Fazit

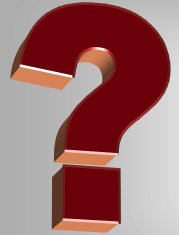

Entscheidung für
welche
Netzwerkhardware und
Kommunikations-
infrastruktur

Ethernet

Switched
Ethernet

TCP/IP

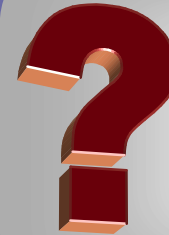

Entscheidung für
welche Software und
Kommunikationslogik

SOAP

HTTP

XML

Kommunikationsdurchgängigkeit erreicht bei
Netzwerk, Hardware und Software

Outlook

- SOAP Anpassung des wbk μ -Webserviceproviders
 - Weiterentwicklung des Hardwarekonzeptes (Microcontroller mit TCP/IP-Stack)
 - LowCost SOAP Anbindung für Microcontroller
-
- SOAP Parser für Micro-Controller
 - Echtzeituntersuchungen an SOAP-Steuerungsnetzwerken
 - Konfiguration der Netzwerke im rauen industriellen Umfeld

Live-Demo

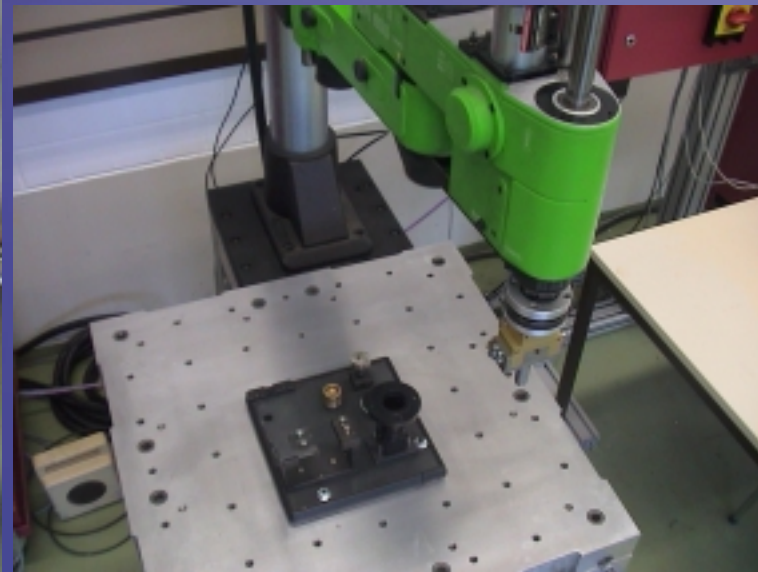
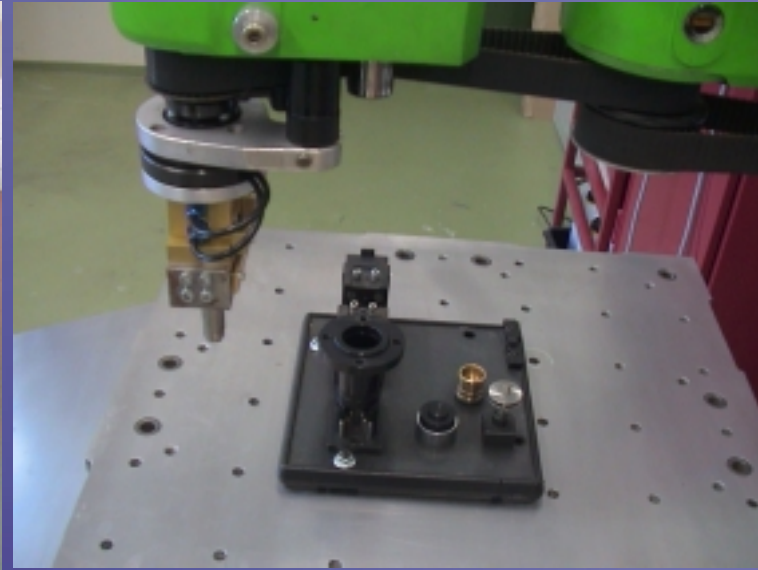
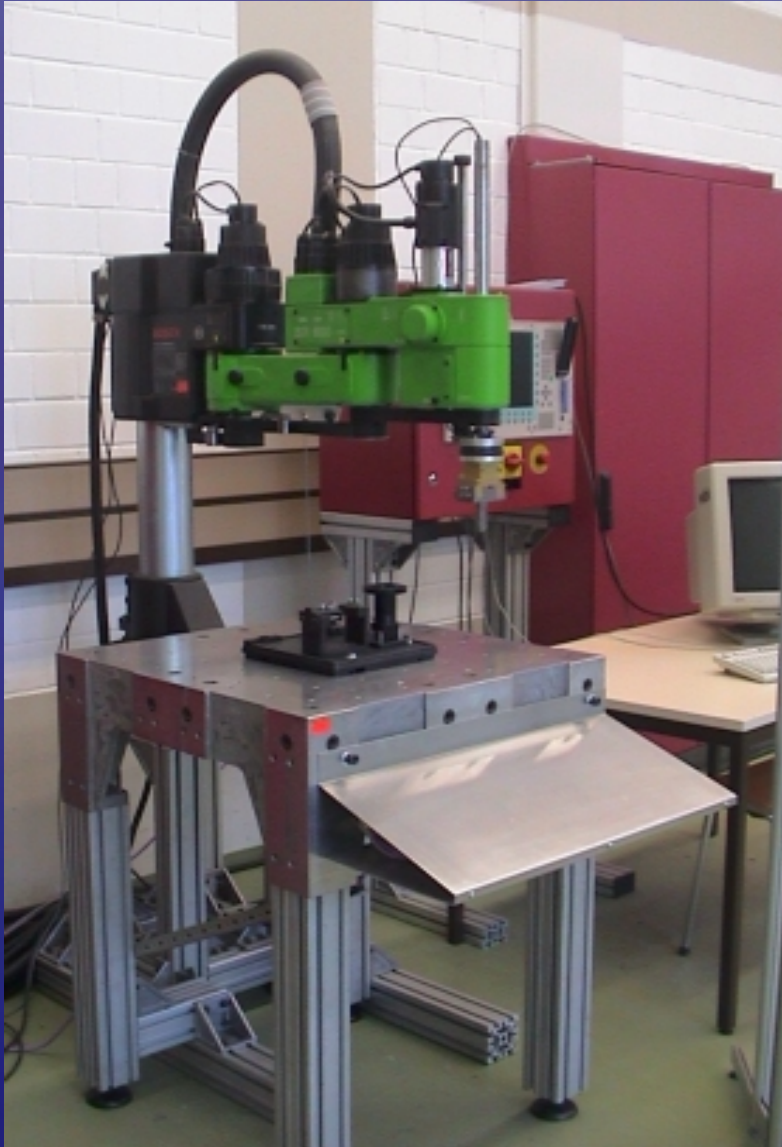

Questions? / Fragen?

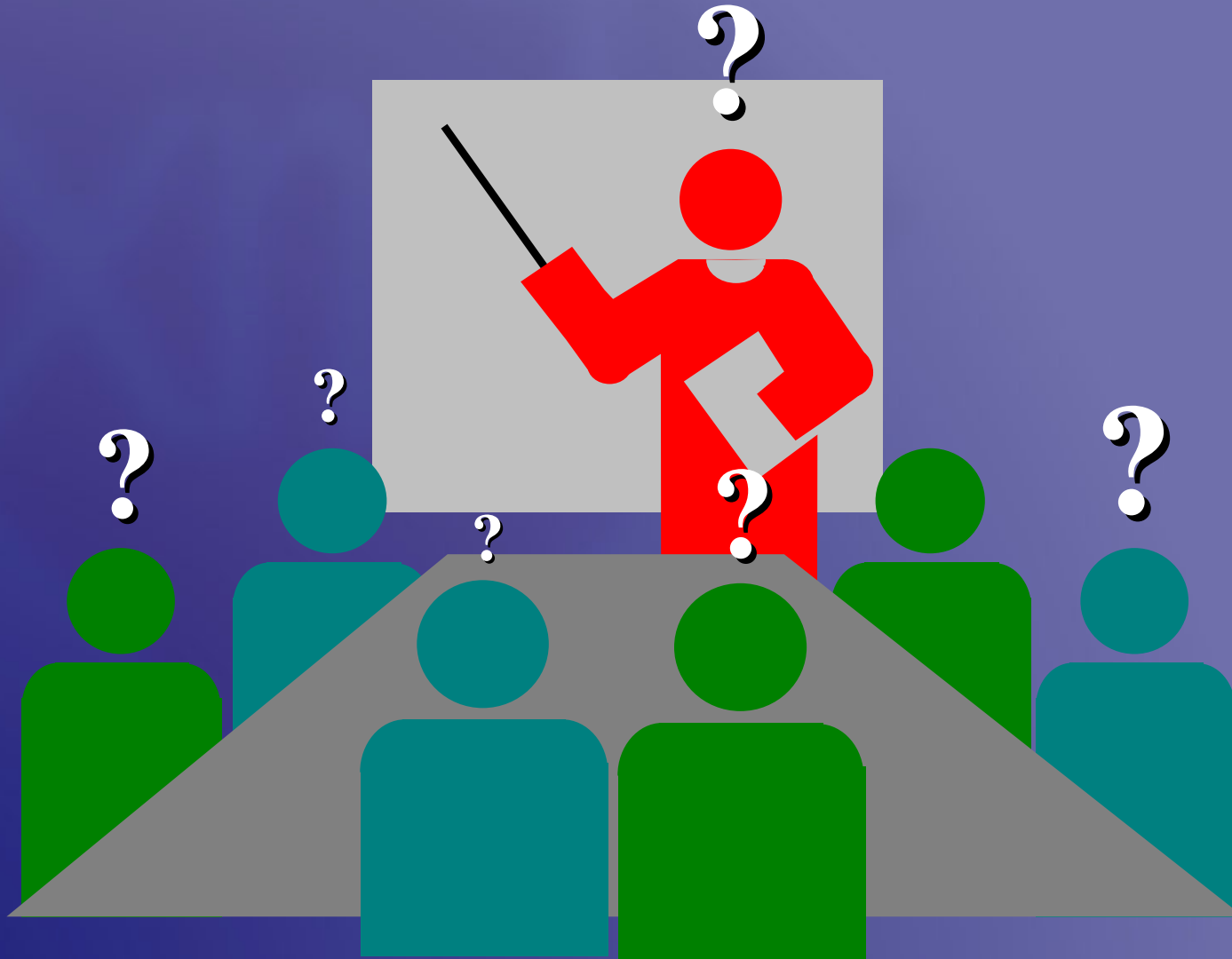

Further Information

Mehr Informationen

Online :

- www-wbk.mach.uni-karlsruhe.de/index_en.html
- www.biztalk-center.com
- www.microsoft.com/mind/0100/soap/soap.asp
- msdn.microsoft.com/workshop/xml/articles/xmlmanifesto.asp

Literatur :

Ethernet TCP/IP für die Industrieautomation

Frank J. Furrer, Hüthig-Verlag

Switched and Fast Ethernet

Breyer, Robert; Riley Sean, MacMillan Computer Publishing Emeryville, USA 2nd Edition, 1999, ISBN 1-56276-426-8

Ethernet-TCP/IP: Hindernisse, Lösungen und Chancen für ein neuartiges Steuerungsnetz

Spath, D.; Landwehr, R.; Gönnheimer, C., Kongress zur SPS/IPC/DRIVES 2000 - Elektrische Automatisierungstechnik - Systeme und Komponenten, November 2000, Nürnberg

Glossary / Glossar

- ARP: Adress Resolution Protocol
- RARP: Reverse Adress Resolution Protocol
- IP: Internet Protocol
- GGP: Gateway-to-Gateway Protocol
- EGP: Exterior Gateway Protocol
- RSVP: Resource Reservation Protocol
- ICMP: Internet Control Message Protocol
- IGMP: Internet Gateway Multicasting Protocol
- OSFP: Open Shortest Path First Protocol
- TCP: Transmission Control Protocol
- UDP: User Datagram Protocol

- HTTP: Hypertext Transfer Protocol
- XML: Extensible Markup Language ;-)
- SOAP: Simple Object Access Protocol
- SGML: Standard Generalized Markup Language

- WSDL: Web Service Deskription Language
- WSML: Web Service Meta Language
- ASP: Active Server Pages
- ISAPI: Internet Server API
- API: Application Programming Interface

- CSMA/CD: Carrier-Sense Multiple-Access/Collision-Detection

- COM: Component Object Model
- DCOM: Distributed COM
- OPC: OLE for Process Control
- OLE: Object Linking and Embedding
- CORBA: Common Request Broker Architecture
- SIS: Service Information System
- SPS: Speicherprogrammierbare Steuerung
- PLS: Programmable Logic Control
- AT: Automatisierungstechnik

Slide reserved for Mission Statement